

(No Model.)

6 Sheets—Sheet 1.

W. S. BURROUGHS. CALCULATING MACHINE.

No. 388,117.

Patented Aug. 21, 1888.

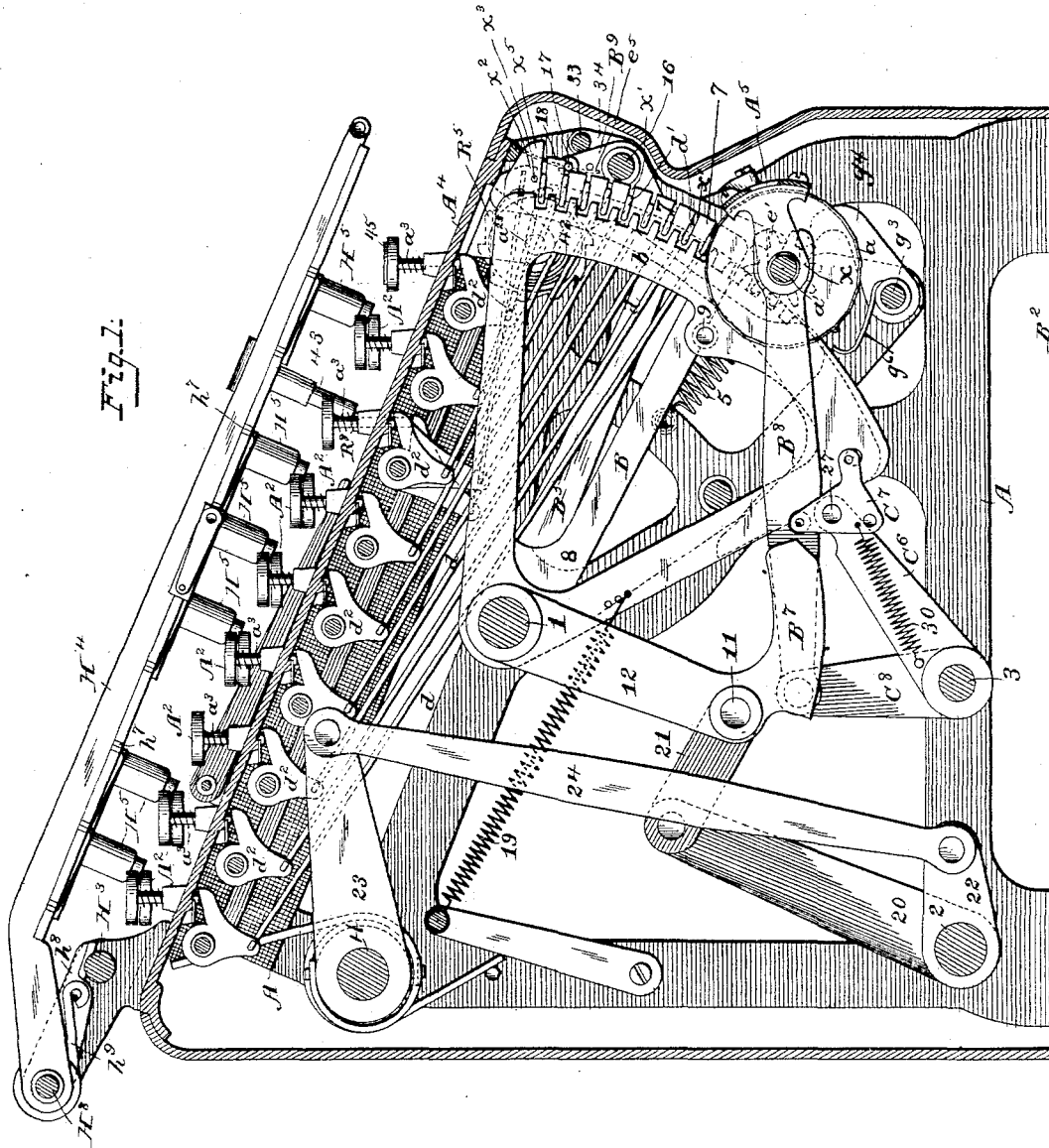

Fig. 1.

Attest:
Curtis Cooper.

H. C. Lammann.

W. S. Burroughs.

Inventor.

Wm. J. Freeman.

Atty.

(No Model.)

6 Sheets—Sheet 2.

W. S. BURROUGHS.
CALCULATING MACHINE.

No. 388,117.

Patented Aug. 21, 1888.

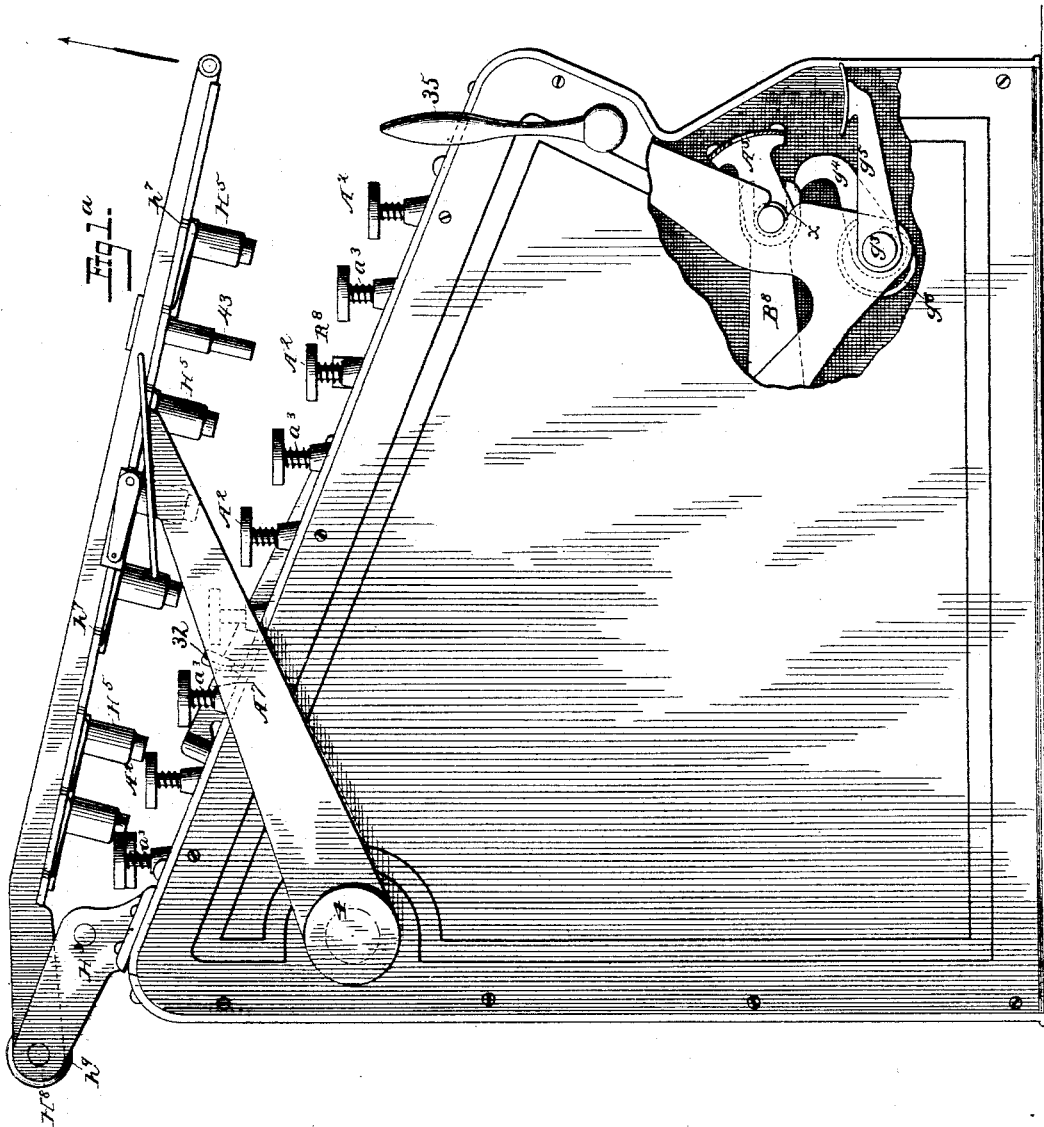

Attests:

John H. ...
Wm. A. Harris

W. S. Burroughs.

Inventor:

Wm. ... & Freeman
Atty.

W. S. BURROUGHS.
CALCULATING MACHINE.

No. 388,117.

Patented Aug. 21, 1888.

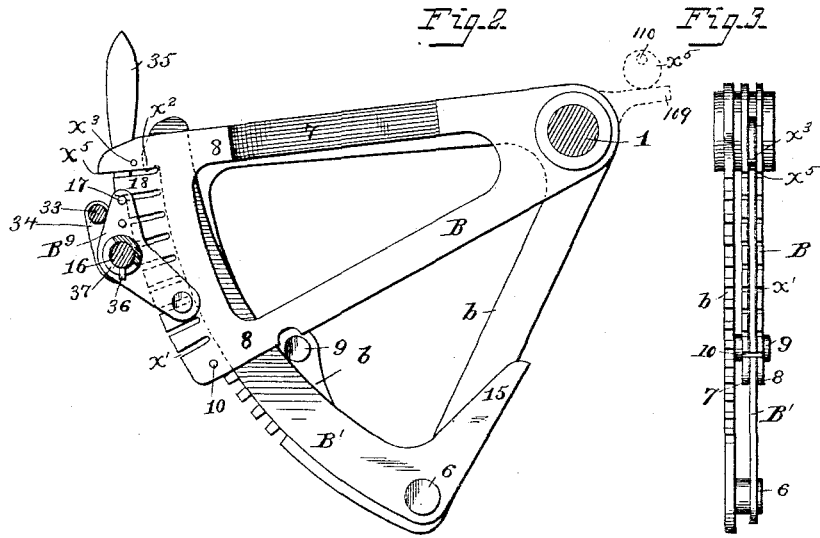

Fig. 4.

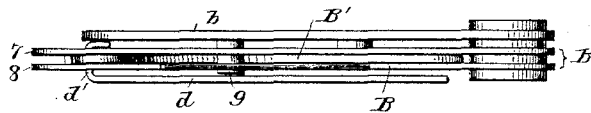

Fig. 5.

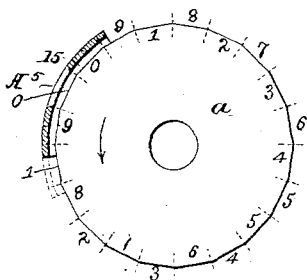

Fig. 6.

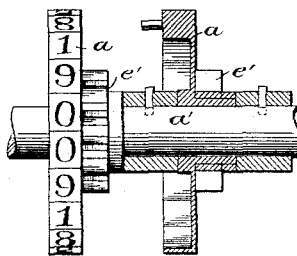
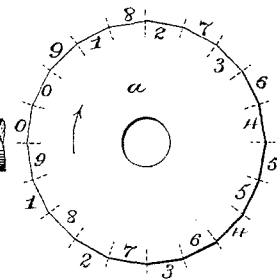

Fig. 7.



Attest:
Count. Cooper.
R. G. Hansmann.

Wm. S. Burroughs,
 Inventor:
By Foster & Freeman
 Atty.

W. S. BURROUGHS.
CALCULATING MACHINE.

No. 388,117.

Patented Aug. 21, 1888.

Fig. 5.

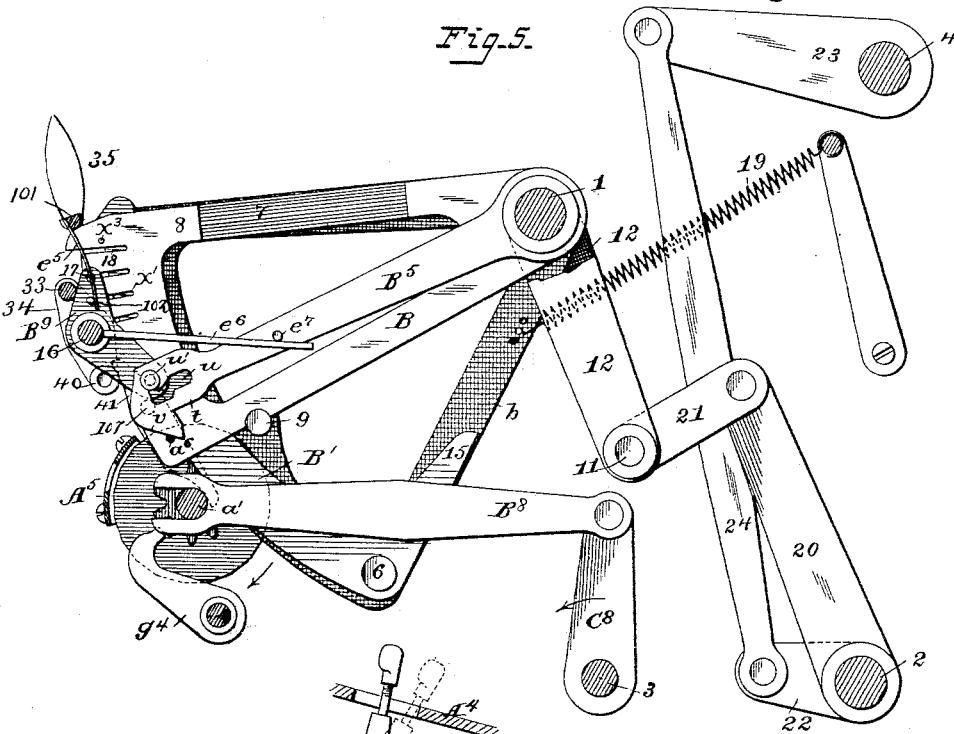
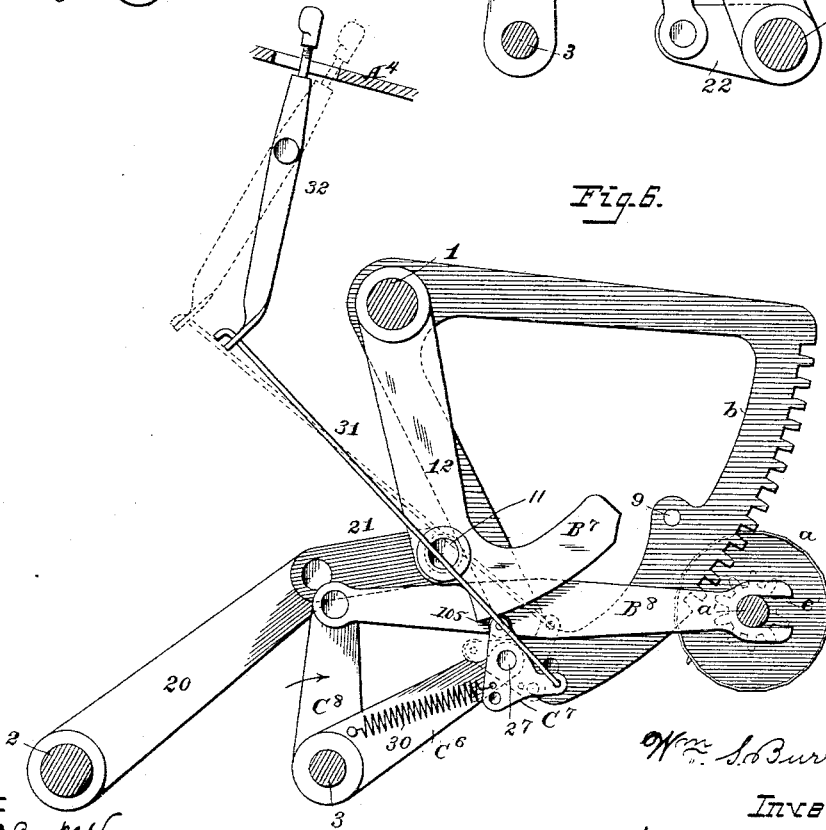

Fig. 5.



Attest:
Court Reporter,
H. C. Hansmann.

W. S. Burroughs,
Inventor:
J. J. Freeman,
Atty.

(No Model.)

6 Sheets—Sheet 5.

W. S. BURROUGHS.
CALCULATING MACHINE.

No. 388,117.

Patented Aug. 21, 1888.

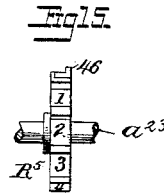
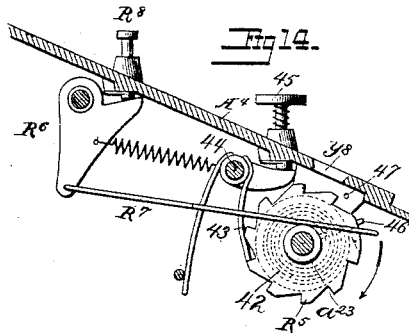
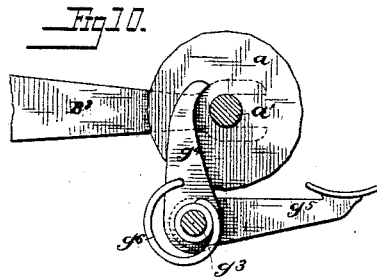

Attest:
[Signature]
 Wm A. Harris

W. S. Burroughs,
 Inventor:
 By *[Signature]* J. L. Freeman
 Atty.

W. S. BURROUGHS. CALCULATING MACHINE.

No. 388,117.

Patented Aug. 21, 1888.

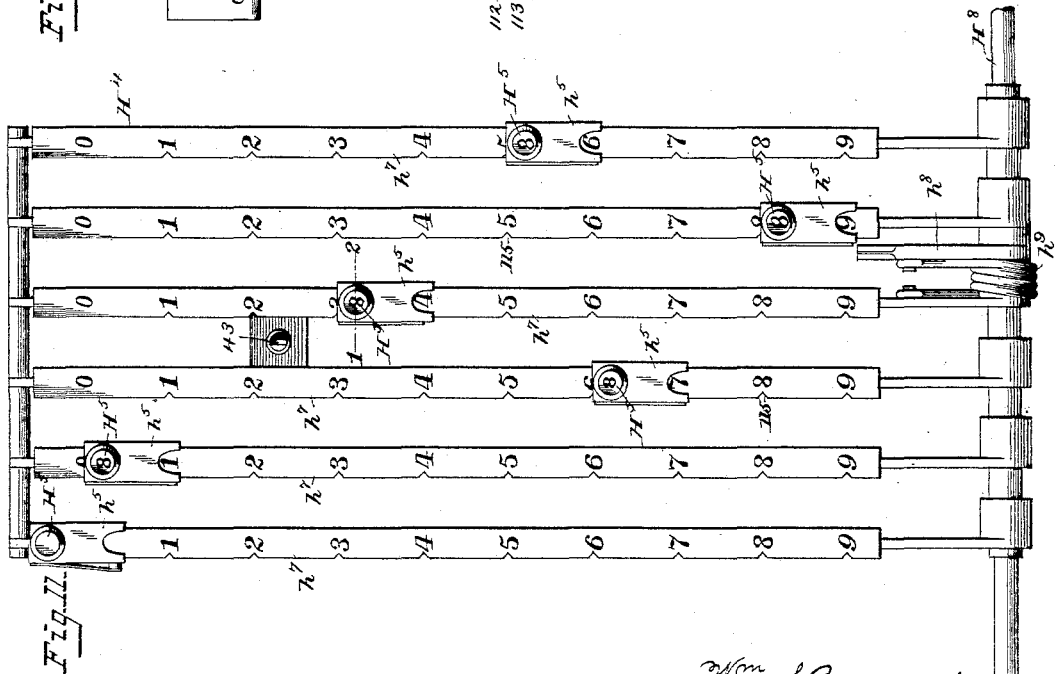
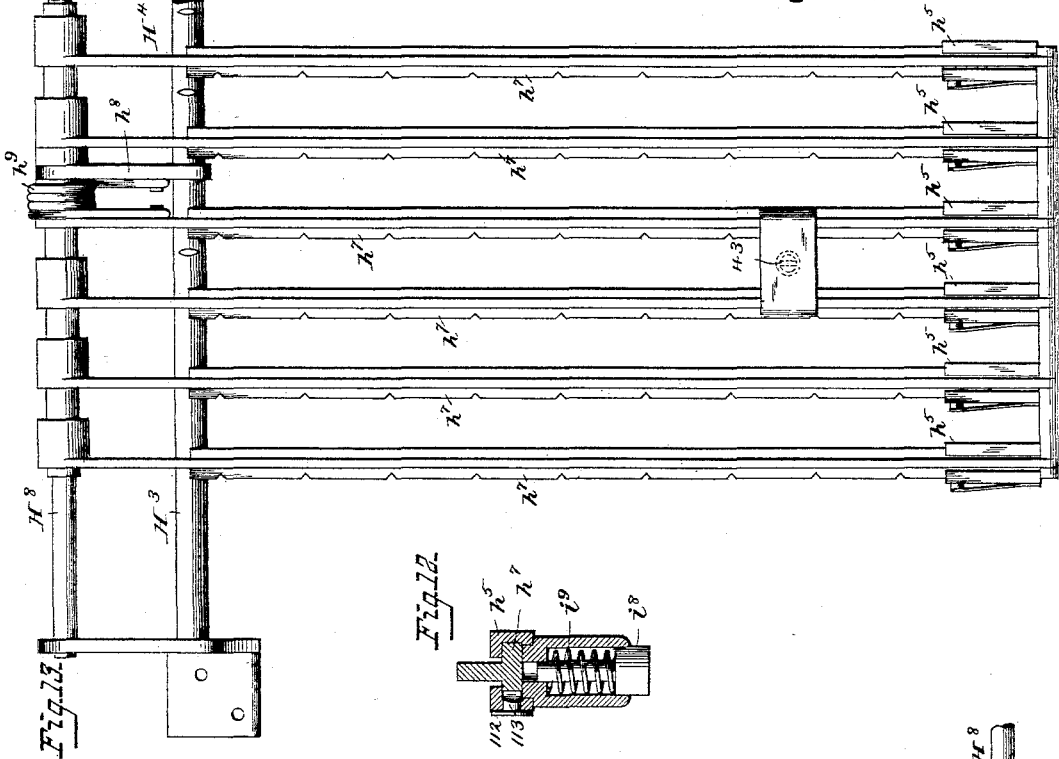

Attest:
Court A. Cooper.
H. C. Hansmann.

Wm. S. Burroughs
 Inventor:
John S. Freeman
 Atty.

UNITED STATES PATENT OFFICE.

WILLIAM S. BURROUGHS, OF ST. LOUIS, MISSOURI, ASSIGNOR, BY DIRECT AND MESNE ASSIGNMENTS, TO THE AMERICAN ARITHMOMETER COMPANY, OF SAME PLACE.

CALCULATING-MACHINE.

SPECIFICATION forming part of Letters Patent No. 388,117, dated August 21, 1888.

Application filed August 17, 1885. Serial No. 174,593. (No model.)

To all whom it may concern:

Be it known that I, WILLIAM S. BURROUGHS, a citizen of the United States, and a resident of the city of St. Louis, State of Missouri, have
5 invented certain new and useful Improvements in Mechanical Accountants, of which the following is a specification.

My invention relates to apparatus for performing mechanically various arithmetical operations; and my invention consists in certain improvements upon the apparatus for which I filed application for Letters Patent January 10, 1885, Serial No. 152,485, said improvements consisting in the construction and arrangement
15 of the parts, as fully set forth hereinafter, so as to permit the adjustment of the register-wheels to effect operations in addition, multiplication, subtraction, and division.

In the accompanying drawings, Figure 1 is a side elevation, in part section, showing that portion of the machine which is inside the outer frame. Fig. 1^a is a side elevation of the machine. Fig. 2 is a side view showing one of the levers and its annexed segment and the lever-operating devices. Fig. 3 is an edge view of the lever and segment. Fig. 4 is a plan view of the lever and segment, showing one of the stops and rod connected therewith. Fig. 5 is a side view showing the lever, segment, indicator, operating devices, and lock-bar. Fig. 6 is a side view illustrating devices for operating upon the segments and indicators. Fig. 7 is an edge view, in part section, of the registering device. Figs. 8 and 9 are side views of one of the register-wheels. Fig. 10 is a detached view showing a hand device for throwing the indicators out of connection with the segments. Fig. 11 is an inverted plan view of the multiplier device. Fig. 12 is an enlarged section on line 1 2, Fig. 11. Fig. 13 is a reverse top view of Fig. 11, showing the rod H³, on which the device slides. Fig. 14 is a sectional view of the devices for registering the movements of the multiplier-frame. Fig. 15 is a front view of one of the wheels of the said register.

The side pieces of the frame A are connected by means of the base B² and key-board A¹. In the side frames are supported rock-shafts
50 1, 2, 3, 4, and 16, and in slots x in the side

pieces or attachments thereto lies a shaft, a' , which is drawn toward the closed ends of the slots by means of a spring, 5, at each end. The shaft a' carries the register, consisting of a series of numbered wheels or "indicators," a ,
5 each having a pinion, e' , at one side, which pinion gears with the teeth of a toothed segment, b , hung to the side of a sector-lever, B, and both swinging loosely on the shaft 1.

Between each lever B and its sector b is a
60 detent or locking device, B', whereby each sector can be temporarily secured in position on and be caused to move with the lever, and whereby it may be released, to fall by its own weight independently of the lever, thereby
65 turning the adjacent wheel in the direction of its arrow, Fig. 9. The detent may be of any suitable character. As shown, it consists of an arm, B', pivoted to the sector b at 6, and said arm extends between two parallel plates,
70 7 8, Fig. 4, which constitute the lever B, upward, and is limited in its vibration by two stops, 9 10, the former on the sector b and the latter connecting the plates 7 8; and the detent has a lip, x^2 , (see Fig. 2,) at the upper
75 end for catching on a pin, x^3 , of the lever B when the lever B and sector are locked in position.

The extent to which the sector drops will determine the extent to which the wheel is
80 turned and the number presented opposite a sight-plate, A⁵, and to regulate the dropping of each sector I use a series of keys, A³, Fig. 1, sliding in the key-board, and stops d' , which are adjusted by the keys through the medium
85 of levers d^2 and rods d . Each stop d' , Fig. 4, is formed by bending the end of the rod d at right angles to the rod, and the stop slides in slots x' in the parallel plates 7 8, and as a rod
90 d is drawn back by depressing a key the stop d' bears against the forward edge of the arm B' and swings it to carry the lip x^2 away from the pin x^3 , when the sector will fall until the lip
95 x^2 catches on the stop d' , which has been carried inward. This action is substantially the same as that in my machine for which I applied for Letters Patent on the 10th day of January, 1885, Serial No. 152,485, and as in this and in other features the two machines are very much alike I will not refer very mi- 100

nutely herein to construction and operations common to both machines.

There are in this machine twelve series of keys, A^2 . Each key is raised by a spring, a^3 .

5 There is an indicator-wheel, a , to each series of keys, and the shaft a' , which carries the series of indicators, (together constituting the register,) can slide in the slots x , so as to carry the pinions e' of the indicators into and out of
10 gear with the teeth of the segments.

As in the description of the other machine, I term the devices (which may vary in character) between each indicator and each key of the corresponding series the "connections."

15 I term the devices which hold the sectors in normal position the "locking devices." I term the devices actuated by the different keys to arrest each sector after it has fallen the proper distance the "stops," and I term
20 the means for restoring all the dropped sectors simultaneously to their normal positions a "restoring device," the restoring device in this case consisting of a bar, 11, carried by arms 12 12, swinging on the shaft 1, which bar,
25 when swung forward, strikes the fallen sectors and swings them upward until their lips x^2 lock with the pins x^3 .

Each arm B' , Fig. 2, has a tail-piece, 15, which projects beyond the edge of the sector
30 b and is struck by the bar 11, so as to throw the arm B' forward and force out the stop d' to its first position and insure the catching of the locking-lip x^2 on the pin x^3 when the sector reaches its highest position.

35 In this machine, as in the other, it is necessary to turn each indicator representing higher values one step when the adjacent indicator of lower value takes the last step of its revolution, and this is done, as in the other
40 machine, by means of an actuating device operating independently of the keys and automatically turning each wheel one step at the proper time whether the sectors b be down or up and whatever may be the positions of the
45 other parts of the connections. The devices for effecting this are the levers B , each of which is combined with devices for imparting to it automatically a limited motion sufficient to turn the wheel with which it is connected

50 one step. As the lever B carries the toothed sector, it is necessary to drop the lever only a short distance to turn the wheel through the medium of the sector and pinion, and each lever is held in an elevated position by an L-shaped trip-arm, B^9 , Figs. 2 and 5, on the
55 shaft 16, which arm carries a pin, 17, that engages with a long tooth, 18, of the lever B and sustains the latter. The lever B pertaining to each wheel must derive its motion from the
60 next wheel of lower value as the latter completes its revolution—that is, as the figure 9 on the said wheel is carried from opposite the sight-plate opening. This is effected by causing each wheel of lower value as it completes
65 its revolution to trip the arm B^9 , so as to carry the pin 17 away from the tooth 18, when the lever B of the next wheel of higher value

(which is supported by said trip-arm) will drop until a shoulder, x^5 , rests on the pin 17, the downward motion of the lever and segment being just sufficient to turn the second or wheel of higher value one step.

It will of course be evident that different means may be used for sustaining each lever B in its upper position and for releasing it as
75 the next wheel of lower value completes its revolution, which means will be obvious to any skilled mechanic. I therefore do not limit myself to the means shown; but they have proved effective and are specially useful for
80 the purpose of bringing all the wheels to zero, as will be hereinafter set forth.

When the restoring-bar 11 lifts the sectors b , they will rise until the pins 9 strike the levers B , when both will rise until the teeth 18
85 escape the pins 17, when the arms B^9 will swing inward until the pins 17 are under the teeth 18, which then rest on the pins. I lock each arm B^9 by means of a locking-bar, B^5 , hung to the shaft 1, Figs. 1 and 5, and having
90 an inclined terminal edge, v , adapted to engage with a pin, a^6 , on the next wheel of lower value, and an L-shaped slot, u , adapted to receive a pin, u' , projecting from the side of the lower branch of the arm B^9 . The weight of
95 the bar B^5 normally retains the pin u' in the vertical part of the slot u , whereby all rocking movement of the arm B^9 is prevented; but as the next wheel of lower value completes a revolution its pin a^6 strikes the beveled edge
100 v and lifts the locking-bar until the pin u' is opposite the longitudinal part of the slot u , when a spring, e^5 , fast to a bar, 101, of the case and bearing on a pin, 102, on the arm B^9 , causes the arm B^9 to swing until the pin 17 es-
105 capes from the tooth 18, permitting the lever B to drop.

It will be seen that whenever the pins a^6 come in contact with the bars B^5 the next wheels are moved a step, regardless of whether
110 the said wheels are at the time stationary or in the act of moving from their operating-sectors, having already been released. In the former case the wheel is moved one step. In the latter it is moved an additional step.

115 Any other suitable device may be used for locking the arm B^9 . Thus, the pin a^6 may strike and operate the arm directly; but it is best to use a locking device to prevent the arms from getting displaced. It is sometimes
120 requisite to throw out all the arms B^9 simultaneously by hand. This I effect by turning the shaft 16 by its handle 35, and springs e^5 , that bear on the arms B^9 , throw them back as soon as the lock-bars B^5 are elevated, this ele-
125 vation resulting from the contact of rigid fingers e^6 on the shaft 16 with pins e^7 on the lock-bars.

The sectors b may fall by their weight. I prefer, however, to connect to them springs
130 19, which carry them downward.

The restoring-bar 11 is swung from the rock-shaft 2 through the medium of an arm, 20, and connecting-link 21, and the shaft 2 is

rocked from the shaft 4 through the medium of arms 22 23 and connecting-rod 24, the shaft 4 being provided at the end with a hand-lever, A⁷, Fig. 1^a, for rocking it. As it is often desirable to swing the registers out of connection with the sectors as the latter are lifted, I employ connections between the hand-lever A⁷ and the register-supports for effecting this result. For instance, I provide the rock-shaft 3, Figs. 1, 5, and 6, with arms C⁸, to each of which is jointed a bar, B⁸, forked at the end to receive one end of the shaft *a'* of the register, so that when the shaft 3 is rocked in the direction of the arrow, Fig. 6, the shaft *a'* will be carried forward and the pinions of the register will be carried from gear with the teeth of the sectors. The shaft 3 is rocked from the shaft 1 by means of a curved shoe or cam, B⁷, extending from one of the arms 12 and engaging with a lever, C⁷, on an arm, C⁶, carried by the shaft 3 and depressing the arm C⁶ by its beveled end making contact with a roller, 105, of the lever C⁷ and rocking the shaft 3 and throwing out the register when the shaft 1 is rocked to restore the sectors to place.

In some instances in subtracting it is necessary to restore the sectors to place while the register is in gear with said sectors. This I effect at such times by moving the lever C⁷ so that the cam B⁷ will not act thereon. Thus the lever C⁷ swings on a pivot, 27, and is held in the position shown in Fig. 6 by a spring, 30. A rod, 31, connects the lever C⁷ with a hand-lever, 32, which, when moved to the position shown in dotted lines by hand, swings the lever C⁷ to the position also shown in dotted lines, Fig. 6, when the shaft 1 will rock without bringing the cam into contact with the lever C⁷.

Each arm B⁹ swings freely on the shaft 16 to a limited extent, and a bar, 33, is carried by arms 34, extending from said shaft, so that by rocking the shaft 16 by means of the handle 35 the bar 33 can be brought against all the arms to swing them simultaneously inward. The bar 33 is brought against all the arms B⁹ just as the plates B are brought to their elevated position, and the lock-bars B⁵ then drop and secure the arms B⁹.

The wheels *a*, Figs. 7 and 8, have each a series of figures from 0 to 9 at equal distances on their peripheries, and these are arranged so that by the operation of the keys, as described in my former application, the sums of any numbers will be indicated through the openings in the sight-plate A⁵, Figs. 1, 1^a, 5, and 8. In addition to this series of figures I place a second series of figures on each wheel from 0 to 9, but running in the reverse direction, and these are placed alongside of or, as shown in Fig. 7, intermediate with those of the first series on the same peripheral line, each wheel being moved at each step sufficiently to expose succeeding numbers of the series then being used. In Figs. 8 and 9 the figures indi-

cate the relative positions of those on the peripheries.

The sight-plate instead of being fixed, as in my other machine, is capable of a limited movement, so as to expose in its upper position the numbers on the wheels pertaining to the adding series and in its lower position the numbers pertaining to the subtraction series.

When it is required to perform the operation of subtraction, the wheels of the register are all adjusted by hand to bring the signs 0 of the adding series opposite the sight-opening, the sight-plate being in its upper position. The signs 0 of the subtraction series cannot in the arrangement shown be brought opposite the sight-opening when the sight-plate is in either position, as the pins *a*⁶, by striking the shoulders *t* of the locking-bars B⁵, arrest the wheels only in the position with the 0-signs of the adding series exposed. The 9-signs of the subtraction series will therefore be in position to be seen when the sight-plate is lowered. All the wheels of the register are now thrown out of gear with the sectors by moving out the shaft *a'*, when the first step of subtraction may be performed. The minuend is first set up. In order to set up the minuend, the register is first thrown forward to carry the pinions all out of gear with the sectors, in order that the sectors may be set in position independently of the pinions. The registers are moved out by drawing forward the lever 35, and thus rocking the shaft 16, until the pins or arms 40 thereof, Fig. 5, strike and swing levers 41, which vibrate on pins 107 and bear on the shaft *a'* and carry it forward in the slots in the frame. As the lever 35 is moved forward and turns the shaft 16 and lifts the rods *e*⁶, the lock-bars B⁵ are lifted and the arms B⁹ are set at liberty, as then the pins *u'* can pass into the horizontal parts *u* of the slots. Each arm B⁹ is now moved out at the upper end by the action of the spring *e*⁶ until the pin 17 passes from beneath the long tooth 18 and the sector B drops one step until the shoulder *a*⁵ rests on the pin 17. The register is held in this position until the keys setting the minuend are all struck.

Suppose it be required to subtract 113 from 228. The first figure of the minuend 228 at the right is 8, and the key 8 of the right hand or first series is struck, when the sector *b* for actuating the first indicator will drop eight steps without turning the wheel. The key 2 of the second series is then struck, dropping the second sector two steps, and the key 2 of the third series is struck, dropping the sector of the third wheel two steps, or all the keys 8 2 2 of the three series are struck simultaneously with like effect. The register is then thrown inward to bring the pinions into gear with the sectors, and the latter are all restored to their normal or upper positions by means of the restoring mechanism, the upward movements of the sectors turning the wheels backward. As the first sector was dropped by the action of

key 8 eight steps, and as the withdrawal of the pin 17 from the tooth 18 dropped the segment in addition one step, the sector was dropped nine steps altogether, and consequently when it is turned back by restoring the sector to place it will turn back the wheel nine steps or points and bring the number 8 opposite the sight-opening, with the plate A⁵ in its lowest position. This is illustrated in Fig. 8. The wheel is first in the position shown in Fig. 8, the 9-sign of the subtraction-series in position to be exposed when the sight-plate is lowered, and the 0-sign of the addition series in position to be shown when the plate is raised. If the actions before described dropped the first sector only eight points, the lifting of the sector would turn the wheel in the direction of its arrow eight points and would bring the figure 7 of the subtraction series opposite the sight-opening. For this reason the sector was dropped eight points by the action of the key and one point by the action of the arm B⁹, so that the restoring of the sector to position turns the wheel nine steps, and thereby brings the figure 8 of the subtraction series opposite the opening, thus indicating the first figure of the minuend. The necessity of adding one results from the fact that the register when set at zero on the addition series must show "9" on the subtraction series, which number (9) is one step less than zero. So in turning back the wheel to exhibit any number on the subtraction scale it must be turned one step more than that number to compensate for starting one step less than zero. As each sector is dropped one step by withdrawing the pin 17, all the wheels will be turned back one step when the sectors are lifted, and the figure exposed on the wheels not actuated by the keys will be 0, the next figure after 9 on the subtraction scale. The second key struck in setting up the minuend was key 2, dropping the second sector two steps in addition to the step it was dropped by withdrawing the pin 17, so that the wheel is turned back three steps as the sector rises and the figure 2 is brought opposite the opening. The like effect results from striking the key 2 of the third series of keys, and the result is the exposure of the figures 2, 2, 8, as the minuend through the sight-openings of the sight-plate. The minuend being thus set up, the register-wheels being in gear with the sectors, the operation of subtracting the subtrahend 113 is effected by striking the keys, as in addition. Thus the key 3, corresponding with the lowest figure of the subtrahend, is struck. Then the key 1 of the second series of keys and the key 1 of the third series of keys, or all the keys, 3, 1, 1, of the three series, are struck simultaneously, or from left to right. The wheel of lowest value, showing the figure 8, Fig. 9, is turned in the direction of the arrow as the sector descends in gear with the pinion of said wheel, and as the sector descends three steps the wheel is turned three steps, thus bringing the figure 5 opposite the opening.

The next wheel, showing the figure 2, is turned one step by the descent of the sector one step on striking the key 1, and the figure 1 is exposed, as also results with the third wheel, the result being that the number 115 is exposed, that number being the remainder after subtracting 113 from 228.

It is often necessary to remove the register from connection with the key-connections or register-actuating devices. This is effected by means of a shaft, g^3 , Figs. 1 and 10, carrying two arms, g^4 , which may be brought against the shaft a' to carry it outward by depressing the end of an operating lever or handle, g^5 , Figs. 1^a and 10, a spring, g^6 , retracting the arms. When the two series of numbers on the wheels are arranged on the peripheries side by side instead of alternately in line, the action and operation will be the same and the sight-plate will be adjusted longitudinally instead of being moved up and down.

The two series of numbers may of course be upon separate disks or indicators.

I have described means for imparting an extra movement to each segment in addition to that effected by the action of the keys for the purpose of moving the wheels one step farther than would be effected by the keys alone; but this may be done without varying the movements of the segments. I have done it by hand by turning the shaft a' first in one direction and then in the other, and other different means may be employed.

Other means than those described may be used for imparting to each lever B a movement sufficient to turn each wheel one step—as, for instance, an eccentric, x^2 , on a shaft, 110, and bearing on an arm, 109, projecting from the lever, as shown in dotted lines, Fig. 2.

To facilitate multiplication, I use the device which I will now describe.

At the top of the key-board is a rod or guide, H³, for a sliding frame, H⁴, and upon the latter are notched guides, h^1 , for adjustable fingers H⁵, corresponding in number with the number of places or figures in the greatest sum it may be desired to multiply. Each finger is secured to a slide, h^2 , carrying a catch or spring, 112, with a pin, 113, engaging frictionally with the notches in the guides h^1 , so as to hold each finger above any one of the keys, according as it is set in place. The frame H⁴ carries a pivoted arm, h^3 , Figs. 1, 11, and 13, which bears upon a rod, H², parallel to the rod H³, and a spring, h^4 , connected to the arm and frame, tends to hold the frame in a horizontal position, but yields to permit it to be depressed to carry the fingers against and depress the keys A². To prevent noise and too abrupt impact, each finger is provided with a projecting buffer-block, i^2 , bearing against a spring, i^1 , Fig. 12. Each guide h^1 is graduated or numbered on the under side, as shown in Fig. 11. Either the multiplier or the multiplicand may be set up on the multiplier device. If, for instance, it is desired to multiply 17,496 by 834, the multiplicand, being the

larger number, is preferably set up on the multiplier device by putting the right-hand finger, H^5 , opposite the number 6, the next opposite the number 9, and so on, as shown in Fig. 11. The frame is then brought to a horizontal position and slid to the left until the right-hand finger, H^5 , is above the line of keys in the highest place of the multiplicand in the notation. Thus, as the highest place in the number 834 is hundreds, the finger H^5 at the right is brought above the third or "hundreds" row of keys. The frame is then depressed as many times (eight) as there are units in this place. Then it is moved to the next lowest place and again depressed as many times (three) as there are units in this place, and then it is again moved to the lowest place and depressed as many times (four) as there are units in this place. The result will be that the product of $834 \times 17,496$ will be shown as 14,591,664 through the sight-opening of the plate A^5 in its highest (or addition) position.

As the operator may forget the number of times he has operated the frame, I use a register, which registers each operation. This register is shown in Figs. 14 and 15 as consisting of a series of numbered ratchet-wheels, R^5 , supported on a shaft, a^{23} , below the key-plate A^4 , opposite holes y^8 in the latter, and a bell-crank lever, R^6 , and pawl R^7 to each wheel, each pawl being connected to the arm of the lever R^6 and engaging with the teeth of the ratchet-wheel. A pin, R^8 , extends through a hole in the key-plate A^4 and bears on the horizontal arm of the lever R^6 , said pin being arranged to be struck by a stationary finger, 43, on the frame H^4 . Each downward motion of the frame turns one of the wheels R^5 one step, and this registers the number of strokes, which register can never exceed 9. A coiled spring, 42, secured at one end to each wheel R^5 and at the other end to the shaft a^{23} , tends to turn the wheels R^5 in the direction of the arrow, and a pawl, 43, secured to a shaft, 44, serves to hold each wheel after each movement; but the shaft 44 may be rocked by a push-button, 45, so as to carry all the pawls 43 out of engagement with the wheels, when the springs 42 will restore them to zero, a projection, 46, on the periphery of the wheel adjacent to the zero-sign striking a pin, 47, on the key-plate to stop each wheel when it has been turned to exhibit the zero-sign.

The multiplying device, instead of operating on the keys, may operate directly on the stops d' with the same effect, in which case the frame H^4 would be arranged to vibrate in front of the machine.

It will be obvious that the frame H^4 may be constructed in any suitable manner to support the movable finger H^5 , and the latter may act on any of the moving parts that will effect the adjustment of the disks.

The multiplying device may be combined and used with different forms of calculators having keys or parts capable of being operated by the fingers of the frame, and the latter

may be moved upon bearings instead of swinging on a pivot.

The operation of division may be performed with the same appliances by first setting up the dividend in the same manner as a minuend is set up, then set up the divisor on the frame, and operating in the same manner as in multiplication.

I claim—

1. The combination, with the register of a mechanical calculator provided with a series of independently adjustable wheels, with a series of keys to each wheel, each wheel having two series of numbers from 0 to 9 in line with each other on the periphery of the wheel, but in reverse order, of a sight-plate adjustable so as to exhibit the numbers of either series without showing those of the other series, and register-wheel-operating devices whereby each wheel is moved a distance equal to that between the adjacent numbers of one series at each movement, substantially as described.

2. The combination, with a register consisting of a series of wheels, each provided with two series of numbers from 0 to 9 alternating in one line with each other on the periphery of the wheel, but in reverse directions, of numbered keys and connections whereby the wheels can be turned by operating the keys in one direction to set up a minuend corresponding to the numbers on the keys, and reversing devices and connections whereby the wheels are reversed from the second action of the keys in striking the subtrahend to indicate a number corresponding to the difference between the minuend and subtrahend, substantially as described.

3. The combination of the register having wheels provided with two series of numbers from 0 to 9 in reverse order, keys, intermediate operating devices between each key and its wheel, and adjustable bearings for the register to carry the wheels to and from the said operating devices, substantially as described.

4. The combination, with a series of register-wheels provided with two series of numbers arranged in reverse order, of a series of keys to each wheel and wheel-operating devices constructed to be set in different positions, according to the key struck, adjustable bearings for the wheels, whereby they may be moved into and out of connection with said devices, and a restoring device whereby the operating devices may be simultaneously restored to their normal position after being set by the keys and after the wheels are in connection therewith, substantially as described.

5. The combination of a series of wheels numbered with two series of numbers in reverse order, a series of keys to each wheel, intermediate operating devices whereby each wheel is operated to an extent determined by the key struck, actuating devices independent of the keys, whereby each wheel is turned one step as the next lowest wheel completes its revolution, and adjustable bearings for the wheels, whereby they may be carried into and

from connection with the operating devices, substantially as described.

6. The combination, with the series of indicator-wheels, of a lever, B, to each wheel, provided with stops, stop-adjusting keys connected with said stops, an actuating-sector for each wheel carried by each lever, and appliances, substantially as described, for imparting a limited movement to each lever to turn the wheel one step, for the purpose set forth.

7. The combination of the registering-wheels, a series of keys, pivoted levers B, each carrying a series of stops actuated by the series of keys, a movable toothed segment carried by each lever, and a movable bearing supporting each lever, substantially as set forth.

8. The combination, with each registering-wheel and with each series of keys and stop devices, of an adjustable lever supporting the said stop devices and a movable toothed segment gearing with a pinion connected with the lever, and a movable locking-arm carried by the segment and serving in connection with the stop devices to determine the movement of the segment and the wheel, substantially as set forth.

9. The combination, with the indicator-wheels, their actuating-segments, stop devices, and movable levers B, carrying the segments, of arms having bearings for the levers and locking bars constructed to hold said arms in one position and to be operated by pins upon the wheels to release the arms to take a different position, substantially as set forth.

10. The combination, with register-wheels, movable bearings for the register-wheels, the operating-segments, and restoring-bar, of a cam moving with said bar, an arm connected

to the bearings of the register-wheels, and an adjustable bearing upon the arm adapted to be thrown into and out of contact with the cam, for the purposes set forth.

11. The combination, with the indicator-wheels, operating-segments, and levers B, of a shaft carrying arms B', affording bearings for the levers B, springs bearing against the arms to throw them outward, and a movable bar, arranged to be brought against the arms to swing them simultaneously inward, substantially as set forth.

12. The combination, with a mechanical calculator having a register, of a movable frame provided with guides and adjustable fingers arranged to be brought in contact with the parts of the machine actuating and regulating the movements of the register, substantially as set forth.

13. The combination, with the key-board and registering devices of a mechanical calculator and with the keys thereof, of a frame capable of being moved to and from and across the keys and provided with a series of adjustable fingers, substantially as set forth.

14. The combination of a mechanical calculator, a movable frame carrying a series of adjustable fingers, and a registering device, arranged to register the number of the movements of the frame, substantially as set forth.

In testimony whereof I have signed my name to this specification in the presence of two subscribing witnesses.

WILLIAM S. BURROUGHS.

Witnesses:

JOSEPH BOYER,
EDWARD HOTCHKISS.