

A. SCHOENHUT.
JOINTED FIGURE.

APPLICATION FILED JULY 3, 1909.

Patented Jan. 17, 1911

2 SHEETS—SHEET 1.

982,096.

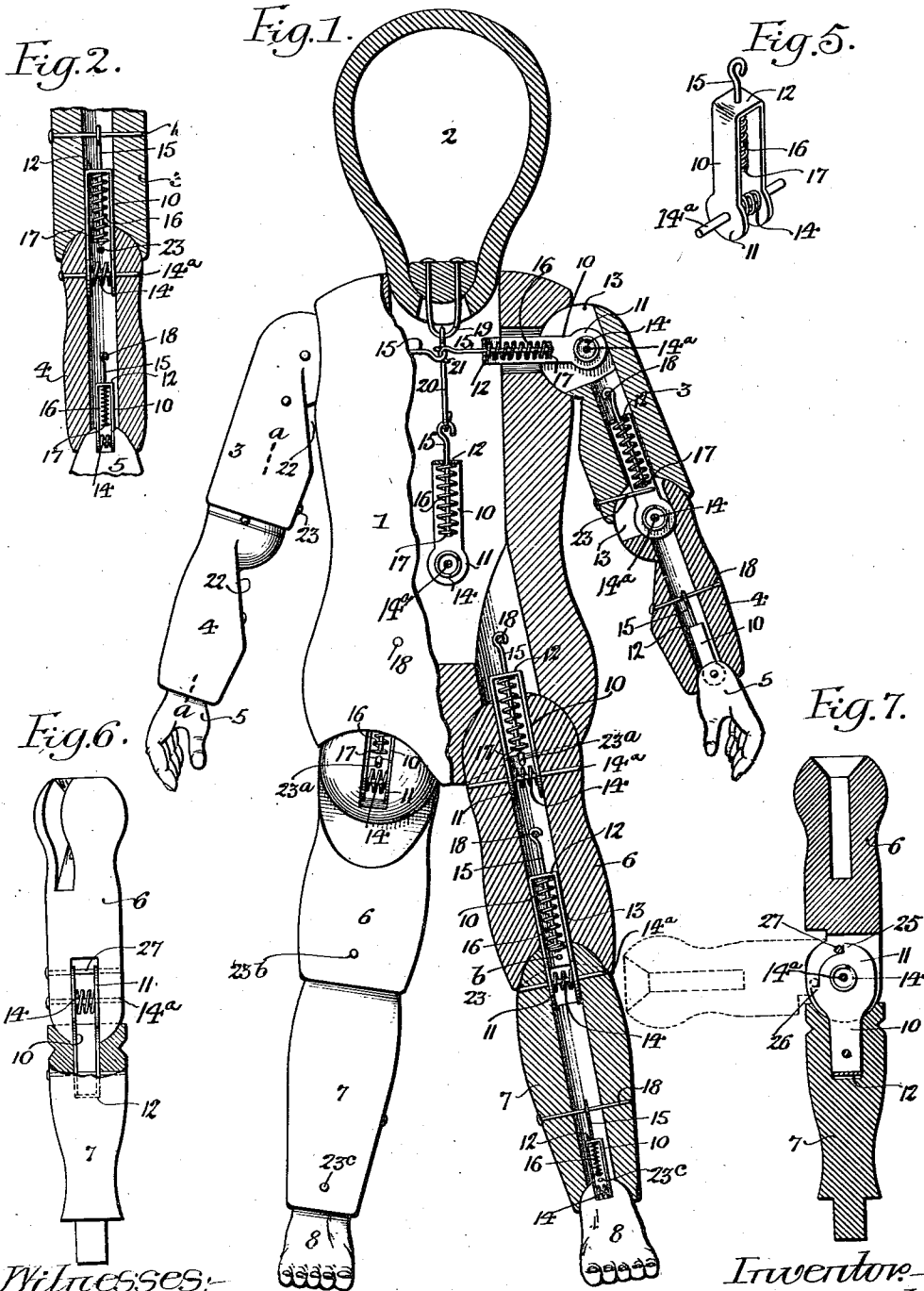

Witnesses:
Titus H. Irons.
Walter K. Pullinger.

Inventor:
Albert Schoenhut.
by his Attorneys,
Housson & Housson

982,096.

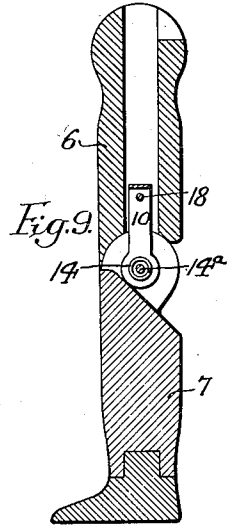
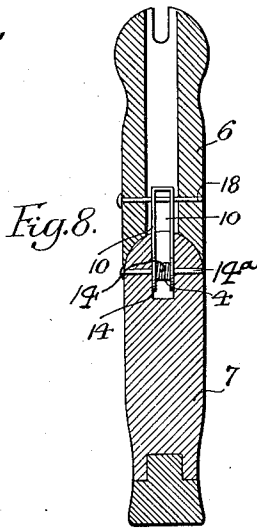
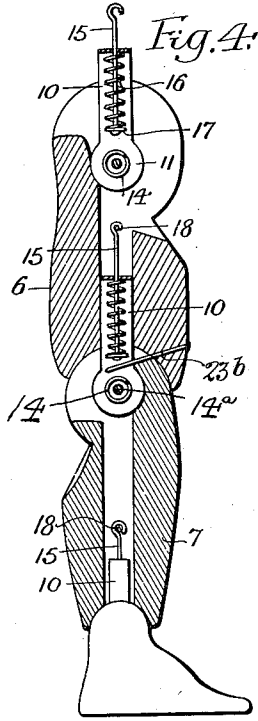
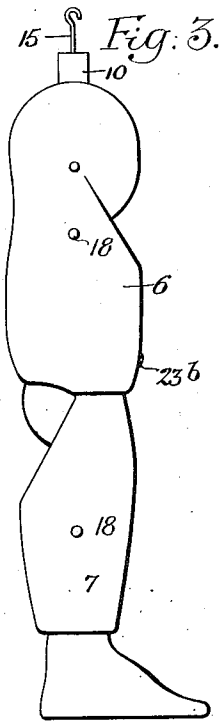

Fig. 10.

Fig. 11.

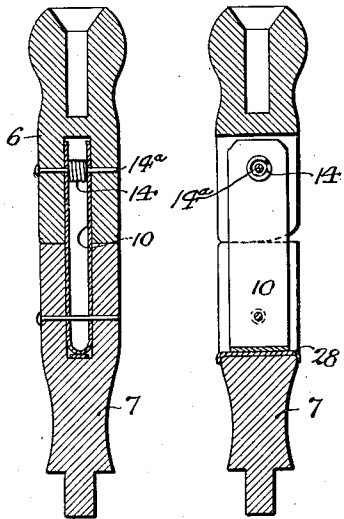
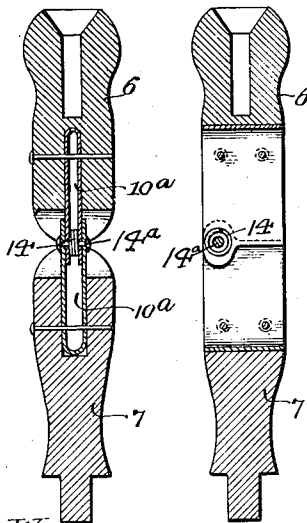

Fig. 12.

Fig. 13.



Witnesses:
 Leticia Irons,
 Walter Pullinger

Inventor:
 Albert Schoenhut,
 by his Attorneys,
 Houson & Houson

UNITED STATES PATENT OFFICE.

ALBERT SCHOENHUT, OF PHILADELPHIA, PENNSYLVANIA.

JOINTED FIGURE.

982,096.

Specification of Letters Patent. Patented Jan. 17, 1911.

Application filed July 3, 1909. Serial No. 505,806.

To all whom it may concern:

Be it known that I, ALBERT SCHOENHUT, a citizen of the United States, residing in Philadelphia, Pennsylvania, have invented certain Improvements in Jointed Figures, of which the following is a specification.

My invention relates to toy figures, manikins, jointed dolls, and the like, and the object of my invention is to provide a structure of this character with means serving to articulate the several members, such means being of a character as to insure the maximum degree of friction whereby the several limbs and portions of the same may be turned and held in various positions assumed by such turning operations without danger of disarrangement except at the desire of the person using the toy, doll, or jointed figure. In addition, the means which I have provided for articulating the structure are so arranged as to insure movement of the several limbs substantially in accord with the movement of the several limbs of the human body.

The essential feature of my invention is the character of the hinge joints between the body and limbs and between the sections of the several limbs.

My invention is fully shown in the accompanying drawings, in which:

Figure 1, represents a front elevation of a jointed doll made in accordance with one embodiment of my invention; such doll being shown partly in section; Fig. 2, is a sectional view on the line *a-a*, Fig. 1; Figs. 3 and 4, are respectively a side elevation and a section of the thigh and leg of the figure shown in Fig. 1; the section being taken on the line *a-a* thereof; Fig. 5, is a perspective view illustrating one form of my improved joint; Figs. 6 and 7, are views similar to Figs. 3 and 4, illustrating another form of joint, and Figs. 8, 9, 10, 11, 12 and 13 are views illustrating various forms of joints embodying my invention.

In the drawings herewith, 1 represents the trunk of the figure; 2 the head; 3 the upper arm portions; 4 the lower arm portions; 5 the hands; 6 the thigh portions; 7 the leg portions, and 8 the feet.

The joint for use between the limbs and the trunk and between the several sections of the limbs of the figure shown in Fig. 1, is fully illustrated in Fig. 5, and comprises a folded piece of material, preferably sheet metal indicated at 10, having enlarged bear-

ing surfaces 11 at one end and a connecting portion 12 at the opposite end, such element being of a width to fit the recesses or slots 13 in the end of the several limbs and forming a double walled metal structure adapted to lie against the walls of the same. To maintain the sides of said member 10 in contact with the walls of said recesses or slots, I provide a tension device, which may be in the form of a coiled spring 14, or may be a section of rubber or other suitable resilient material, preferably encircling a pivot pin 14^a passing through said member 10.

Carried by the member 10 is a swivel pin or bar 15 having a spring 16 interposed between the end wall 12 of the joint member 10 and the head 17 of such swivel bar; and said swivel bar may be secured to the body or to the limbs, preferably by means of pins or nails 18 passing through the walls of the trunk of the body and the walls of the several sections of the limbs.

The head, which may have the usual contracted neck portion, fits a suitable opening in the upper portion of the body and may be provided with a loop 19 to which a link 20 may be connected, and the lower end of said link may be attached to a swivel pin or bar 15 carried by one of the elements 10 with the usual spring 16; said element 10 being suitably anchored within the body by a pin 14^a. The upper arm joint connections may be provided with swivel pins or bars with hooked ends 21 which may interlock with each other. In the other instances, the swivel pins may be and preferably are secured by the nails or pins 18 passing through the walls of the figure or the limbs thereof.

The connection for the head is such as to permit said head to move in a complete circle. The connection for the upper arms is such as to permit complete rotary movement of the same; a ball and socket joint being provided, and such arms are rabbeted at 22 so as to permit them to lie close to the body. The connection of the forearm with the upper arm, which is of the ball and socket type, is such as to permit movement of such forearm toward and from the arm only, with its rotary movement limited by a pin or obstruction 23 carried by the upper arm and lying between the walls of the joint member 10. The connection of the thigh with the lower portion of the body, also of the ball and socket type, permits movement

of the thigh toward and from the body in a substantially vertical direction with its rotary motion limited by a pin 23^a passing through the body and extending into the space between the walls of the joint member 10. The movement of the knee joint is forward and back like the human knee joint; the rotary motion being limited by a pin or obstruction 23^b extending into the space between the walls of the joint member 10 carried by the leg. The ankle joint between the leg and foot permits slight up and down movement of the foot and slight rotary motion limited by an obstruction 23^c passing through the lower portion of the leg. In all instances, the joints are provided with tension means, preferably the springs 14 between the walls of the joint members 10, with swivel pins or bars permitting the slight rotary movement and with the springs 16 for insuring the holding of such parts in close connection with the rest of the figure. The tension means or springs 14 disposed between the side walls of the joint members hold the latter against the walls of the slots in the several sections of the limbs and thereby insure such an amount of friction as to cause said members to be held in the several positions to which they are moved.

In Figs. 6 and 7, I have shown a form of jointed limb structure in which the thigh portion 6 has a rounded end or ball to fit a socket in the leg portion. The joint connection for these sections is substantially the same as that shown in Figs. 1 to 5, inclusive, with the exception that the ends of said joint member between which the spring is disposed are slightly enlarged and provided with stops 25 and 26, with which a pin 27 carried by the thigh contacts when in the straight and bent positions respectively. In addition, the thigh portion of this limb structure has the slot for the joint connection with the body disposed diagonally with respect to the knee joint.

In Figs. 8 and 9, I have shown sectional views at right angles to each other of another form of joint, substantially the same as that indicated in Figs. 4 and 5; there being, however, no swivel tension connection between the sections. In Figs. 10 and 11, I have shown another slightly modified form of joint with a metal plate 28 at the bottom of the slot to resist any tendency of the folded metal member to wear the same. In Figs. 12 and 13, another form is shown, comprising a pair of folded members 10^a, one of which lies within the other, and each of which is adapted to a slot in the respective leg and thigh portions. These members are held together by a pivot pin, with a spring disposed between the same and providing the necessary tension to secure the desired friction. In all instances, the pur-

pose is to secure tension that will maintain a high degree of friction and insure sufficient resistance to bending or turning of each joint. In addition, the swivel connections with their springs provide for maintaining the several limbs in close frictional contact with the sockets of the body or trunk of the figure.

Although I have shown my improved form of joint and swivel connections for the head, trunk and limbs of a doll or manikin, it will be understood that it may be employed with all forms of animal toys having articulated joints.

I claim:

1. A joint for toy figures comprising a folded section of metal arranged to fit slotted portions of said figures, and having resilient tension means interposed between the side walls of said metal structure whereby the latter are held against the walls of the slot to increase the frictional resistance to turning, with a swivel pin connected to said joint, and a spring interposed between said swivel pin and joint.
2. The combination, in a toy figure structure, of means for joining the limbs and trunk of said structure, ball and socket joints for the limbs and trunk, friction producing means for said joints, and means for limiting rotative movement of the limbs at their ball and socket connections.
3. A joint for toy figures comprising a folded section of metal arranged to fit slotted portions of said figures, spring tension means interposed between the side walls of said metal structure whereby the latter are held against the walls of the slot to increase the frictional resistance to turning, a swivel pin connected to said joint, and tension means interposed between said swivel pin and joint.
4. The combination, in a toy, doll, or figure structure, comprising a trunk and articulated limbs, of means for joining the limbs and trunk of said structure, means combined with said joints for increasing the frictional resistance of said limbs to turning, and pins extending through the structure adjacent the joints for limiting rotative movement of the limbs.
5. A joint for toy figures and the like, comprising a folded section of material arranged to fit slotted portions in the limbs of said figures, and having resilient tension means interposed between the sides of said folded material whereby the latter are held against the walls of the slot to increase the frictional resistance of the joints to turning, with a swivel member connected to said joint, and tension means interposed between said swivel pin and joint.
6. The combination, in a jointed toy, doll, or figure structure, of means for connecting the limbs and trunk of said structure, means

for increasing the frictional resistance of the joints to turning, means for limiting their bending movement, and means for limiting rotative movement of the limbs of such structure.

7. A joint for toy figures and the like, comprising a folded section of material arranged to fit slotted portions of the limbs of said figures, a coiled spring interposed between the sides of said folded material whereby the latter are held against the walls of the slot to increase the frictional resistance of the joints to turning, a swivel member connected to said joint, and a spring interposed between said swivel pin and joint.

8. The combination, in a toy doll, or figure structure, comprising a trunk and articulated limbs, of means for joining the limbs and trunk of said structure, means combined with said joints for increasing the frictional resistance of said limbs to turning, means for limiting the bending movement of the joints, and pins extending through the structure adjacent the joints for limiting the rotative movement of the limbs.

9. The combination, in a jointed figure, of a socketed trunk, limbs adapted to said sockets, anchors for said limbs, swivel connections between the anchors and the limbs, tension means for the swivel connections, joint members attached to said swivel connections, and means for directly applying tension to the pivot portions of said joints.

10. The combination, in a jointed toy, doll or the like, of a sectional limb, a swivel connection for the sections of said limb, tension means for said swivel connection, and a friction joint for said sections, said joint being attached to the swivel connection and engaging the walls of a slot in one section of said limb.

11. The combination, in a toy, doll, or figure structure, of ball and socket joints for the limbs and trunk of said structure, means for pivotally connecting the limbs and trunk at such ball and socket connections, means for increasing the frictional resistance to turning at said pivotal connections, and means for limiting rotative movement of the limbs at their ball and socket connections.

12. The combination, in a toy, doll, or figure structure, of ball and socket joints for the limbs and trunk of said structures,

means for pivotally connecting the limbs and trunk at such ball and socket connections, the limbs being slotted for such pivotal connections, means for increasing the frictional resistance to turning at said pivotal connections, and means carried by one limb member and entering the slotted portion of another for limiting rotative movement of the limbs at their ball and socket connections.

13. In a toy figure having elements with slotted portions pivotally connected therewith, a jointing element comprising a double-walled metal structure arranged to fit said slotted portions, the walls of said metal structure lying in engagement with the walls of said slotted portions, and resilient tension means interposed between the walls of said metal structure directly at its pivot point whereby said metal walls are held against the walls of the slotted portions to produce frictional resistance to turning.

14. In a toy figure having elements with slotted portions, a jointing element comprising a double-walled section of metal arranged to fit said slotted portion and engage the walls of the same, a pivot pin carried by said slotted portion, said pin passing through the walls of said metal structure to confine the same to the slotted portion, and tension means interposed between the side walls of said metal structure at the pivotal connection whereby said walls are held against the walls of the slotted portion to produce frictional resistance to turning.

15. In a toy figure having elements with slotted portions, a jointing element comprising a double-walled section of metal arranged to fit said slotted portions with its walls in engagement with the walls of said slotted portion, a pivot pin in said slotted portion passing through the walls of said metal structure to confine the same thereto, and a coiled spring interposed between the walls of said metal structure and surrounding the pivot pin whereby said walls are held against the walls of the slotted portion to produce frictional resistance to turning.

In testimony whereof, I have signed my name to this specification, in the presence of two subscribing witnesses.

ALBERT SCHOENHUT.

Witnesses:

MURRAY C. BOYER,
WM. A. BARR.